

with transference, of the type

Ag | AgCl | KCl ( $m_1$ ) | KCl ( $m_1$ ), glycine ( $m_2$ ) | AgCl | Ag

The molalities of potassium chloride and glycine,  $m_1$  and  $m_2$ , were varied over a range from 0.05 to 0.50. These measurements were used along with accurate transference data to calculate  $\log \gamma_2$  at low glycine concentration, where  $\gamma_2$  is the activity

coefficient of glycine. It was found that at low  $m_2$

$$\log \gamma_2 = -0.1789m_1 - 0.06278m_1^2 + 0.1635m_1^{3/2}$$

From the limiting slope of  $\log \gamma_2$ ,  $-0.1789$ , the dipole moment of the glycine dipolar ion was calculated to be 14.4 Debye units.

ITHACA, NEW YORK

RECEIVED DECEMBER 30, 1940

[CONTRIBUTION FROM THE CHEMICAL LABORATORIES OF COLUMBIA UNIVERSITY]

## Rate and Equilibrium Studies on the Thermal Reaction of Hydrogen and Iodine<sup>1</sup>

BY ALFRED H. TAYLOR, JR.,<sup>2</sup> AND R. H. CRIST

The well-established homogeneous and bimolecular character of the thermal reaction between the hydrogen isotopes and iodine allows theoretical calculations to be made with some certainty. Experimentally the reaction has been studied in the classical researches of Bodenstein<sup>3</sup> and others, and is generally considered to be one of the most carefully investigated gaseous reactions to be found in the literature. A critical review of the kinetics has been given by Kassel.<sup>4</sup>

From the calculated free energy function and the equilibrium constant of Bodenstein<sup>3</sup> for the dissociation of hydrogen iodide, Murphy<sup>5</sup> obtained the free energy as a function of temperature. However, when Murphy plotted  $\log K$  vs.  $1/T$  as derived from his free energy values, the slope was quite different from the best straight line through all the available experimental data. The same calculation has been made for deuterium iodide by Blagg and Murphy,<sup>6</sup> but since the heat of reaction at absolute zero was not available, it was calculated from the equation

$${}^2\Delta E_0^0 = {}^1\Delta E_0^0 + \left( \frac{1}{2} E_{0D_2^0} - E_{0DI^0} - \frac{1}{2} E_{0H_2^0} + E_{0HI^0} \right) \quad (1)$$

where  ${}^1\Delta E_0^0$  and  ${}^2\Delta E_0^0$ , respectively, refer to the reactions

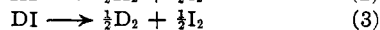
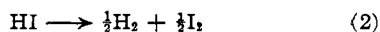

(1) Dissertation submitted by Alfred Henry Taylor, Jr., in partial fulfillment of the requirements for the degree of Doctor of Philosophy in the Faculty of Pure Science, Columbia University.

(2) Present address: The Burroughs Wellcome & Co. (U. S. A.), Inc., Experimental Research Laboratories, Tuckahoe, N. Y.

(3) Bodenstein, *Z. physik. Chem.*, **13**, 56 (1894); **22**, 1 (1897); **29**, 295 (1899). "Habilitationsschrift," Heidelberg, 11-36, W. Engelmann, Leipzig, 1899.

(4) Kassel, "Kinetics of Homogeneous Gas Reaction," The Chemical Catalog Co., New York, N. Y., 1932.

(5) Murphy, *J. Chem. Phys.*, **4**, 344 (1936).

(6) Blagg and Murphy, *ibid.*, **4**, 631 (1936).

and the other terms are the zero point energies of the molecules indicated.

Wheeler, Topley and Eyring<sup>7</sup> have calculated the ratio of the rates of the reaction between the halogens and hydrogen and deuterium, from potential energy surfaces. For the ratio of the rates of formation of hydrogen and deuterium iodides, these authors have given the values 2.6, 2.34, and 2.26 at 575, 700, and 781°K., respectively. This may be compared with the experimental work of Blagg and Murphy<sup>6</sup> on the reverse reaction by making use of the equilibrium constants, that for hydrogen iodide being taken from Bodenstein, and that for deuterium iodide from the calculation of Blagg and Murphy. Thus

$$\frac{k_{HI}}{k_{DI}} = \frac{k_{2HI} K_{DI}}{k_{2DI} K_{HI}} = 1.53 \times 1.23 = 1.88 \text{ (700°K.)} \quad (4)$$

Geib and Lendle<sup>8</sup> determined the ratio of the rates of the combination reactions directly and found the value of 2.45 at 700°K. This is higher but closer to the theoretical value than that of Blagg and Murphy. However, the experimental error of Geib and Lendle is uncertain since they followed the course of their reaction by measuring the extinction coefficient of iodine by a photometric method. Large corrections were found to be necessary on their calibration curves mainly due to their use of white light and their precision is therefore considered low.

The discrepancies between the experimentally determined values and those calculated from theory make desirable a careful redetermination of the equilibrium constant for the hydrogen iodide reaction, as well as a new comparison of the kinetic reactions. The equilibrium constant

(7) Wheeler, Topley and Eyring, *ibid.*, **4**, 178 (1936).

(8) Geib and Lendle, *Z. physik. Chem.*, **B32**, 463-470 (1936).

of the deuterium iodide reaction has not been measured.

**The Equilibrium Constant.**—The equilibrium constant in the present work was calculated according to the equation

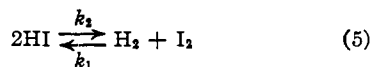

Blagg and Murphy<sup>6</sup> have used the constant for the equation as written in (3).

**The Velocity of Combination.**—The rate constant for the combination reaction is given by the equation

$$k_1 = \frac{0.46051}{t \cdot m} \log \left[ \frac{a + b + m - x(1 - 4K)}{a + b - m - x(1 - 4K)} \right] \left[ \frac{a + b - m}{a + b + m} \right] \quad (6)$$

where  $t$  is in seconds,  $a$  and  $b$  are initial  $\text{H}_2$  and  $\text{I}_2$  in moles cc.<sup>-1</sup>,  $x$  is the HI formed expressed in moles cc.<sup>-1</sup>,  $K$  the equilibrium constant from (5) above and  $m = \sqrt{(a + b)^2 - 4ab(1 - 4K)}$ . This is essentially the equation used by Bodenstein but it has been rearranged to facilitate computation. The dimensions of  $k_1$  are moles<sup>-1</sup> cc.<sup>-1</sup> sec.<sup>-1</sup>.

Kistiakowsky<sup>9</sup> pointed out that for the decomposition reaction the errors involved are smallest when the time of heating is so chosen that a small but uniform amount of reaction takes place. However, in the procedure here the interval required for the reaction cell to come to thermal equilibrium with the furnace is appreciable and the reaction time must be long enough to make this quantity small by comparison. In fact, with the improvements in manipulative and analytical technique which we have obtained, this thermal equilibrium uncertainty becomes the largest factor.

**The Velocity of Decomposition.**—The decomposition velocity constant is given by the following expression adapted<sup>6</sup> from Bodenstein.

$$k_2 = \frac{K^{1/2}}{0.4343ta} \log \left[ \frac{\alpha + Z}{\alpha - Z} \right] \quad (7)$$

Here  $t$  is the reaction time in seconds,  $a$  the initial iodide in moles cc.<sup>-1</sup>,  $Z$  the fraction decomposed at time  $t$ ,  $\alpha = 2K^{1/2}(1 - Z)$  and  $K^{1/2}$  is that written for equation (2).

### Experimental

**Temperature Control.**—Experimental temperatures were measured by a Leeds and Northrup platinum resistance

thermometer calibrated by the National Bureau of Standards. The resistance given by the certificate was duplicated at the ice-point and that at the sulfur point checked to within  $\pm 0.05^\circ$ . Measurement of the thermometer resistance was made on a Leeds and Northrup type G1 Mueller bridge, extended by a calibrated resistance.

The reaction furnace was a well-insulated, electrically heated, aluminum alloy block, drilled to hold four cells. In addition to the main winding over the length of the block, auxiliary heaters were provided in a plate at the bottom and in the plug which closed the furnace at the top. Since the top required the most heat, the body and the bottom plate were shunted separately by incandescent bulbs of various sizes until the cell cavity temperatures as explored by the resistance thermometer at the top, center and bottom were uniform to  $\pm 0.05^\circ$ . Rebalancing was required at each temperature. No difference could be detected among the four cell cavities.

Furnace temperatures were measured by means of a five-junction chromel-alumel thermocouple, mounted in a well at the center of the furnace block and read to  $\pm 0.05^\circ$  with a type K potentiometer. This couple was calibrated in its permanent position by comparison with the platinum resistance thermometer placed in a cell cavity.

All reaction temperatures were controlled to  $\pm 0.1^\circ$  by a four-junction chromel-alumel thermocouple placed in a well near the edge of the furnace block. Differences between the e. m. f. of the couple and that of the balancing potentiometer varied the position of a galvanometer light beam on a bank of three photocells. A null point (an insensitive position) between photocells one and two gave four steps of regulation of the current through the furnace. The balancing potentiometer was not calibrated but interconnecting switches made it possible to adjust the balancing e. m. f. by use of the type K potentiometer. Thus, once the constants of a reaction temperature (steady current in furnace, winding shunts and balancing e. m. f.) had been determined, it was possible to return quickly and accurately to that temperature. E. m. f. hysteresis caused by room temperature changes made it necessary to thermostat the dry cells which furnished the balancing potentiometer working current. In its final form, this regulator could be depended upon to maintain close control when unattended for periods up to twenty hours.

**Preparation of Gases.**—Hydrogen was prepared by electrolysis of sodium hydroxide solution, passed over platinum gauze heated to incandescence in a quartz tube to recombine any oxygen present and then dried by passing through a trap cooled with carbon dioxide. The purified hydrogen was introduced into the evacuated storage bulb through an oblique mercury-filled manometer which equalized the pressure in the bulb with that at which the gases were generated and purified. Deuterium was prepared from 99.9%  $\text{D}_2\text{O}$  in a small electrolytic cell and purified in a system similar to but smaller than that used for hydrogen. An estimate of the hydrogen content of the deuterium was obtained by preparing deuteromethane and determining the isotopic abundance ratio in the mass spectrometer.<sup>10</sup> Deuteromethane is readily prepared by the catalytic reduction of carbon dioxide with deuterium using a thoriated

(10) The isotopic analysis by means of the mass spectrometer was made by Mr. Edgar Leifer.

(9) Kistiakowsky, *THIS JOURNAL*, 50, 2815 (1928).

nickel catalyst in the method described by Russel and Fulton.<sup>11</sup> The ratio of  $CD_4/CD_3H$  was found to be 11/1 which by the equation for the probability of formation  $CD_4/CD_3H = (1 - \alpha)^4/(1 - \alpha)^3$  indicates 2.2% hydrogen in the deuterium. In view of the fact that the catalyst was reduced by hydrogen and that this was the second deuteromethane sample prepared, the actual hydrogen content is probably somewhat less.

Hydrogen and deuterium iodides were prepared by an adaptation of the catalytic method of Cook and Bates.<sup>12</sup> The system used (see Fig. 1) in the present preparation was closed and provided for the recirculation of the unused hydrogen or deuterium by means of a small mercury vapor pump constructed after the design of Prescott and Morrison.<sup>13</sup> The estimated volume of the system was one liter, into which about 10 cm. pressure of hydrogen was put for the average preparation. The pressure dropped as the hydrogen iodide was formed and frozen out, giving an indication of the progress of the reaction. In addition to being very economical of materials, the iodides were produced much more rapidly than with earlier open systems. The iodides were distilled through two traps cooled to  $-80^\circ$  and were snow white as frozen out by liquid nitrogen in the storage trap.

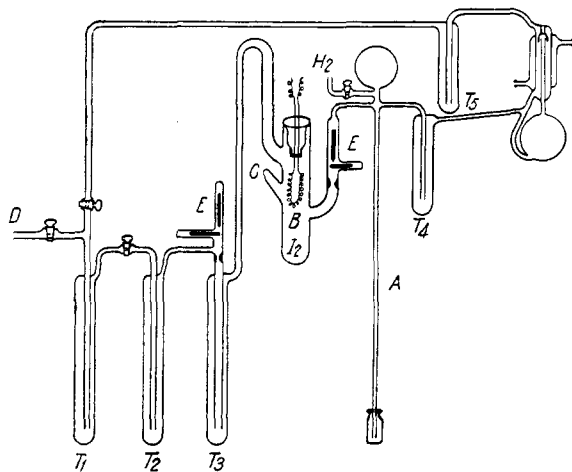

Fig. 1.—Apparatus for the catalytic formation of HI and DI:  $T_1$ , HI storage trap;  $T_2$ ,  $T_3$ , purification traps to remove  $I_2$ ;  $T_4$ ,  $T_5$ , traps to prevent interdiffusion of Hg and  $I_2$ ; A, manometer; B, catalytic chamber; C, entrance tube for  $I_2$ ; D, HI is distilled out through D; E, magnetic valves.

**Procedure.**—The reaction cells were of clear fused quartz approximately 24 mm. outer diameter  $\times$  150 mm. long  $\times$  1.0 to 1.5 mm. thick and of 49 to 55 cc. capacity. One end was adapted for the attachment of the capillary filling tube and bore two hooks to hang from the cell carrier. Cell volumes were determined by filling both tip and cell with water from a calibrated buret. Volumes determined for successive runs frequently checked to  $\pm 0.02$  cc.

The reaction cells were filled in pairs by attaching through graded seals to a manifold (Figs. 2 and 3). To

prepare the cells, they were outgassed at dull red heat for several hours and then stood with hydrogen<sup>14</sup> for three hours, after which they were evacuated. For the decomposition reaction an appropriate amount of hydrogen iodide was transferred to a cell by sublimation for twelve to twenty seconds from  $T_1$  (Fig. 1) held at  $-80^\circ$  to the cell at  $-195^\circ$ . The other traps shown in Fig. 2 were at  $-80^\circ$  to hold possible impurities of low volatility, and any permanent gas was removed by pumping. Great care was exercised to keep mercuric iodide from the cell manifold system. When the process was carried out in semi-darkness the final product was pure white.

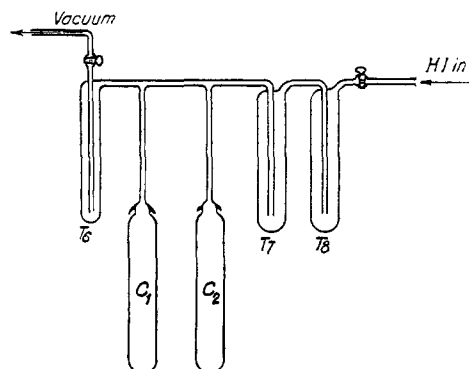

Fig. 2.—Assembly for filling cells with hydrogen iodide:  $C_1$ ,  $C_2$ , cells in place;  $T_6$ ,  $T_7$ ,  $T_8$ , protecting traps.

The reactants for the combination were introduced through the manifold shown in Fig. 3. After conditioning and outgassing as above, 0.10 to 0.15 g. of resublimed iodine was distilled from a side tube into the cell. A magnetically operated plunger served to block the vacuum exit during the transfer of the iodine. After the hydrogen had

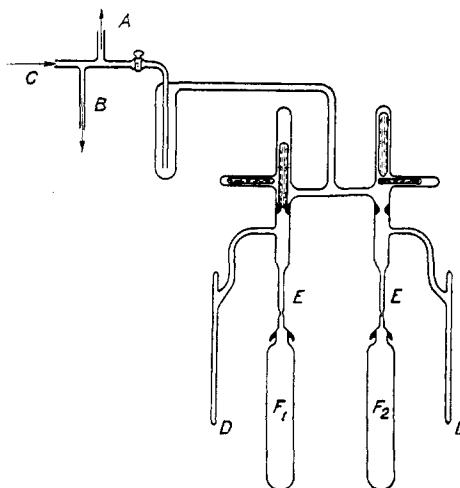

Fig. 3.—Assembly for filling cells with hydrogen and iodine: A, vacuum system; B, manometer; C, hydrogen supply; D, iodine supply; E, graded seals;  $F_1$ ,  $F_2$ , cells in place.

(11) Russel and Fulton, *Ind. Eng. Chem., Anal. Ed.*, **5**, 384 (1933).

(12) Cook and Bates, *THIS JOURNAL*, **57**, 1775 (1935).

(13) Prescott and Morrison, *Ind. Eng. Chem., Anal. Ed.*, **11**, 230 (1939).

(14) This "conditioning" treatment was found to lead to consistent results and was employed throughout the work. Experiments designed to discover the mechanism of the conditioning, however, were not convincing and no explanation is offered.

been introduced, the cells were immersed in water for half an hour to permit thermal equilibrium and the pressure was determined before sealing. The pressure was read on a mercury manometer by means of a steel scale which had been compared carefully with a Bureau of Standards calibrated Invar meter. Correction was made for the expansion of mercury but none was necessary for the scale.

The problem of opening reaction cells and removing without loss the gaseous contents has been attempted in many ways,<sup>3,6,8,9</sup> all of which are more or less unsatisfactory. Since the method employed in this research is rapid and avoids the objections encountered in other methods, it is described in some detail.

A fine scratch (glass knife) was made on the capillary tube at the end of the reaction cell at a point about 5 mm. from the place at which it had been sealed shut. The cell was then inverted in the opening device A (Fig. 4), the end engaged in the socket C and broken. The 4% potassium iodide solution in A rushed into the cell, dissolving the hydrogen iodide and iodine. The cell was lifted out carefully and stood in the flask into which it was to be emptied, the remainder of the potassium iodide and the cell tip being washed into the same flask. After standing for several minutes with occasional shaking to dissolve the cell contents completely, the cell and flask were separated slightly, the capillary drip bend placed in the neck of the flask and the cell next carefully lowered over the shaft of the capillary. By means of the two-way stopcock, either air or water could be introduced, displacing the contents and washing out the cell. The contents were analyzed immediately.

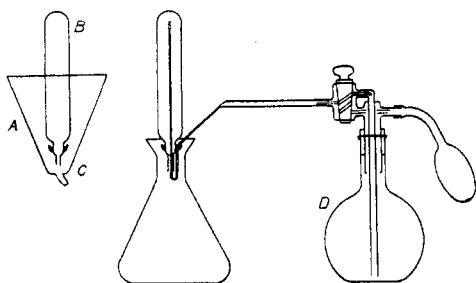

Fig. 4.—Cell emptying devices: A, cell opening device; B, cell; C, socket which engages cell tip; D, special wash bottle with capillary delivery tube.

Reactions were timed to the nearest second by a synchronous electric clock. The introduction of the cells into the furnace required less than ten seconds including opening and replacing the top plug. Just previous to the introduction of the cells, the furnace temperature was increased by an amount experimentally determined to give the most rapid thermal equilibrium. In the shortest runs, the furnace was within  $\pm 0.1^\circ$  of reaction temperature after two minutes, it being  $\pm 0.5^\circ$  (usually  $-0.5^\circ$ ) after one minute. At the end of the reaction time, the furnace was opened and the cells withdrawn and plunged into ice water. The cells were at  $0^\circ$  within eight seconds.

Sodium thiosulfate (0.01 M) was prepared from crystals of analytical reagent grade and boiled distilled water and kept in a lightproof, all-glass container from which it was dispensed by air pressure supplied through a soda lime tube.

Thiosulfate handled in this manner decreased in titer less than 0.02% per month without the use of any preserving agents. The solution was standardized<sup>18</sup> frequently against ceric sulfate which had in turn been standardized against Bureau of Standards sodium oxalate. Standardization by the ceric sulfate method checked to 0.1% with standardization directly against resublimed iodine.

Starch 0.4% solution was prepared daily from Lintner soluble starch and 10 cc. added to each titration. Potassium iodate 4% solution was prepared from analytical reagent and gave no test for acid, iodine or potassium iodide. All titrations were carried out under Mazda illumination filtered by a Corning Daylight filter #590. This method was found to give the most reproducible end-points. All water was freshly boiled distilled water.

Weight burets were used for the thiosulfate and ceric sulfate solutions. Iodine (0.004%) in 4% potassium iodide for back titrations was used from a volumetric buret.

The iodine of the cell contents was first titrated to the starch end-point, 5 cc. of 4% potassium iodate solution added and thiosulfate added from a second weight buret to discharge the color. After twenty minutes, excess thiosulfate was back-titrated to the end-point. Acid blanks and  $I_2/S_2O_3^{2-}$  ratios were determined daily. Correction was made for the amount of reagent required to produce the end-point color.

## Results and Discussion

**The Equilibrium Constants of Hydrogen and Deuterium Iodides.**—The experimental data on the equilibrium constants for hydrogen and deuterium iodides are shown in Tables I and II and in Fig. 5. The initial hydrogen for the combination is given in column 4, and this quantity less that reacted to form hydrogen iodide in column 6. In decomposition experiments, the hydrogen present at equilibrium (col. 6) is the same as the iodine. The iodine and hydrogen iodide were determined by analysis of the equilibrium mixture.  $K_{uncor.}$  (col. 8) is the experimental constant as obtained for equation (5), and the next column gives these values after correction for the diffusion of hydrogen which will be discussed below.

The experimental conditions were arrived at from a consideration of the work of Bodenstein<sup>3</sup> and Kistiakowsky.<sup>9</sup> The plot of  $\log k$  against  $1/T$  of Bodenstein's experimental data shows considerable deviation from a straight line and a proper estimation of the slope cannot be made without some means of weighting the high and low temperature values. It was more convenient in this investigation to reexamine the reaction at the higher temperatures, namely, 666.8, 698.6, 730.8 and 763.8°K. The reaction according to Kistiakowsky is bimolecular between  $2 \times 10^{-5}$  and

(15) Furman and Wallace, *THIS JOURNAL*, **53**, 1283 (1931).

TABLE I  
EQUILIBRIUM DATA FOR HYDROGEN IODIDE

Temp., °K.	Cell	Time, min.	Mol./cc. H <sub>2</sub> start × 10 <sup>3</sup>	Mol./cc. I <sub>2</sub> equil. × 10 <sup>3</sup>	Mol./cc. H <sub>2</sub> equil. × 10 <sup>3</sup>	Mol./cc. HI equil. × 10 <sup>3</sup>	K uncor. × 10 <sup>3</sup>	K cor. × 10 <sup>3</sup>	K av. × 10 <sup>3</sup>
Combination									
763.8	5	140	1.0851	0.28396	0.22754	1.7151	2.195	2.185	
	6	360	1.0833	.36341	.19350	1.7804	2.220	2.203	
	3	140	1.0613	.40569	.17207	1.7788	2.221	2.193	
	4	360	1.0645	.28702	.21930	1.6900	2.202	2.188	
	5	120	1.0970	.25139	.24939	1.6952	2.181	2.172	
	6	120	1.0966	.23054	.26456	1.6641	2.202	2.194	
	1	1380	1.1731	.11851	.42635	1.4936	2.244	2.196	2.192
	3	1380	1.1713	.14776	.38050	1.5763	2.255	2.202	±0.007
Decomposition									
763.8	6	120		.25972	.25972	1.7632	2.170	2.167	
	4	120		.18961	.18961	1.2835	2.182	2.180	
	5	360		.19806	.19806	1.3417	2.179	2.168	2.172
	3	360		.24237	.24237	1.6406	2.182	2.172	±0.004
Combination									
730.8	1	1485	1.1966	.05936	.56170	1.2699	2.067	2.030	
	2	1485	1.2277	.15238	.38415	1.6871	2.057	2.018	
	3	310	1.2009	.09733	.45804	1.4858	2.019	2.010	2.018
	4	310	1.2290	.10577	.45669	1.5445	2.025	2.015	±0.006
Decomposition									
730.8	1	1824		.16958	.16958	1.1807	2.063	2.007	
	4	1824		.14328	.14328	0.9999	2.053	2.009	2.007
	5	1824		.42131	.42131	2.9435	2.049	2.005	±0.002
Combination									
698.6	1 <sup>a</sup>	515	1.1148	.17069	.29070	1.6482	1.827	1.803	
	2 <sup>a</sup>	515	1.1354	.12500	.35600	1.5588	1.831	1.807	
	4 <sup>a</sup>	515	1.1337	.07378	.45647	1.3544	1.835	1.812	
	6	720	1.0678	.23360	.22523	1.6850	1.853	1.829	1.812
	5	720	1.0667	.31292	.18313	1.7671	1.835	1.808	±0.007
Decomposition									
698.6	2	1620		.04789	.04789	0.3531	1.840	1.812	
	3	1620		.11409	.11409	.8410	1.840	1.813	1.811
	6	1620		.04953	.04953	.3655	1.832	1.809	±0.002
Combination									
666.8	1 <sup>b</sup>	1860	1.1193	.12949	.32583	1.5869	1.676	1.642	
	3 <sup>b</sup>	1860	1.1248	.21733	.23941	1.1707	1.656	1.624	1.639
	3 <sup>c</sup>	3600	1.1696	.07014	.46981	1.3997	1.682	1.651	±0.010
Decomposition									
666.8	5	2202		.10084	.10084	0.7816	1.658	1.630	
	1	2202		.07106	.07106	.5468	1.689	1.661	1.645
	6	2202		.13953	.13953	1.0791	1.672	1.644	±0.09

<sup>a</sup> Preheated 910 min. at 653°K. <sup>b</sup> Preheated 2720 min. at 617°K. <sup>c</sup> Preheated 610 min. at 652°K.

$1 \times 10^{-3}$  mole cc.<sup>-1</sup>. The concentrations used here were in the lower part of this range.

The loss of hydrogen by diffusion during the reaction time cannot be neglected. While measurements of the permeability of quartz to hydrogen have been made by Williams and Ferguson,<sup>16</sup> it seemed desirable to determine the rate of

diffusion for our cells. Accordingly, cell 5 was filled to 18 cm. pressure of hydrogen and sealed, and cell 6 used as a control. These cells were enclosed in identical Pyrex jackets connected separately to a MacLeod gage-Pirani filament measuring system, the diffusion of hydrogen at 760°K. being obtained by taking the difference between the pressures in the surrounding jackets.

(16) Williams and Ferguson, THIS JOURNAL, 44, 2160 (1922).

TABLE II  
EQUILIBRIUM DATA FOR DEUTERIUM IODIDE

Temp., °K.	Cell	Time, min.	Mol./cc. D <sub>2</sub> start × 10 <sup>5</sup>	Mol./cc. I <sub>2</sub> equil. × 10 <sup>5</sup>	Mol./cc. D <sub>2</sub> equil. × 10 <sup>5</sup>	Mol./cc. DI equil. × 10 <sup>5</sup>	K uncor. × 10 <sup>2</sup>	K cor. × 10 <sup>2</sup>	K av. × 10 <sup>2</sup>
Combination									
763.8	4	300	1.2272	0.20599	0.37759	1.6992	2.695	2.683	
	2	347	1.1653	.10440	.48095	1.3686	2.680	2.669	
	4	347	1.1623	.12391	.44715	1.4303	2.708	2.696	
	8	240	1.1273	.22547	.31451	1.6256	2.688	2.674	2.677
	7	240	1.1269	.33279	.24766	1.7586	2.679	2.665	≅0.009
Combination									
730.8	1	360	1.1572	.07175	.52914	1.2562	2.406	2.397	
	2	360	1.1495	.10945	.44150	1.4160	2.410	2.400	
	3	360	1.1606	.14721	.39052	1.5401	2.423	2.413	2.398
	4	360	1.1503	.12505	.41438	1.4719	2.394	2.382	≅0.009
Combination									
698.8	1 <sup>a</sup>	2160	1.1565	.08392	.48330	1.3465	2.237	2.192	
	2 <sup>a</sup>	2160	1.1542	.09987	.44866	1.4111	2.250	2.204	
	3 <sup>a</sup>	2160	1.1543	.11968	.41369	1.4812	2.257	2.209	2.204
	4 <sup>a</sup>	2160	1.1519	.10832	.43198	1.4398	2.257	2.210	≅0.006
Decomposition									
698.8	1	1500		.16814	.16814	1.1187	2.259	2.241	2.242
	5	1500		.33756	.33756	2.2448	2.261	2.243	≅0.001
Combination									
666.8	2 <sup>b</sup>	3600	1.1373	.09889	.43026	1.4142	2.127	2.052	
	4 <sup>b</sup>	3600	1.1367	.09369	.43799	1.3974	2.101	2.027	
	1 <sup>c</sup>	7620	1.1415	.12016	.39396	1.4951	2.118	2.022	
	2 <sup>c</sup>	7620	1.1386	.07784	.47656	1.3241	2.116	2.021	
	3 <sup>c</sup>	7620	1.2027	.14255	.38967	1.6261	2.101	2.006	2.019
	4 <sup>c</sup>	7620	1.2019	.08342	.49659	1.4106	2.082	1.988	≅0.015

<sup>a</sup> Preheated 900 min. at 673°K. <sup>b</sup> Preheated 610 min. at 652°K. <sup>c</sup> Preheated 840 min. at 653°K.

The maximum pressure in the jacket of the control system was 4% of that containing hydrogen. To make certain that no spurious air leak was involved, the diffused gas was measured on the Pirani gage calibrated for air and hydrogen. The rate of diffusion was found to be  $0.163 \pm 0.012$

mm. hour<sup>-1</sup>. From the permeabilities given by Williams and Ferguson, this would indicate an average wall thickness of 1.5 mm., which is a reasonable value for the cells used. Diffusion at the three other temperatures was estimated from the data of these authors. The diffusion rates used

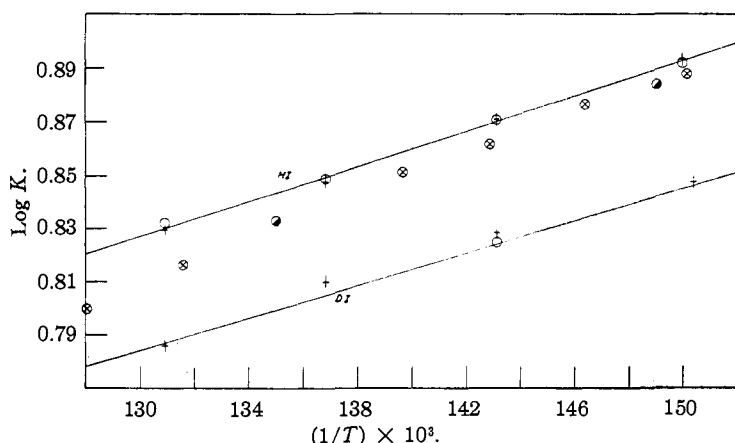

Fig. 5.—Equilibria of hydrogen and deuterium iodides: +, Taylor and Crist, combination; O, Taylor and Crist, decomposition; ⊗, Bodenstein, decomposition; ●, Rittenburg and Urey, decomposition.

are given in Table III, where that for deuterium is taken as  $1/1.41$  of that of hydrogen. The hydrogen pressures for this calculation were taken as an average value up to the equilibrium time and thereafter that at the equilibrium pressure.

The magnitude of the correction made on this basis can be seen in columns 8 and 9 of Tables I and II where there is a maximum of 2% in the last combination run for 763.8°K. In general, the correction was kept low by using minimum reaction times. Hydrogen pressures were much lower in the case of the decomposition reactions, so that the diffusion was less.

TABLE III  
THE RATE OF DIFFUSION OF HYDROGEN IN QUARTZ  
Mol. cc.<sup>-1</sup> min.<sup>-1</sup> cm.<sup>-1</sup> × 10<sup>12</sup>

°K.	H <sub>2</sub>	D <sub>2</sub>
666.8	1.80	1.28
698.6	2.15	1.52
730.8	2.57	1.82
763.8	3.05	2.17

Two systematic errors present are the dissociation of iodine into atoms and the alteration of the equilibrium mixture during the cooling of the system. The first introduces an error of +0.16% at the highest temperature and since this is of the order of the other errors, correction has been omitted. The second error has been neglected as negligible since the entire cooling process required only eight seconds.

Random errors consisted of: analytical, =0.1% as shown by repeated cross checks, giving =0.4% in *K*; measurement of the hydrogen pressure, =0.01 cm. giving =0.16% in *K*; temperature control =0.1° giving =0.05% in *K*; measurement of cell volume =0.05% giving =0.2%; and the diffusion, if in error by 50% leads to =0.3% in *K*. The precision becomes

$$\Delta K = \pm \sqrt{(0.16)^2 + (0.4)^2 + (0.16)^2 + (0.05)^2 + (0.2)^2 + (0.3)^2} = \pm 0.57\%$$

For certain preliminary reactions which have been indicated in the tables, a preheating period at a lower temperature was used. This increases the uncertainty due to diffusion to the extent that a 50% error would give  $\Delta K = \pm 1.2\%$ .

The data are plotted as log *K* against 1/*T* in Fig. 5, the full line for hydrogen being that obtained for the data by the method of least squares. The mean deviation of the experimental points is =0.4%.  $\Delta E_0^0$  calculated from log *K* is 990.40 cal./mole =0.4%. This experimental curve is almost exactly parallel to that calculated by Murphy,<sup>5</sup> and when the increase in  $\Delta E_0^0$  is added to the  $\Delta H_0$  term in his equation<sup>17</sup> the two curves coincide.

Equilibrium values from other authors are included in the figure. Rittenberg and Urey worked with Pyrex and Bodenstein with a Jena glass. While the former glass is not permeable to hydrogen, no information is at hand concerning the latter. Since Bodenstein made a correction

$$(17) -R \ln K = \frac{\Delta F^0}{T} = \frac{\Delta H_0}{T} - \Delta \Gamma_0 \ln T - \frac{1}{2} \Delta \Gamma_1 T - \frac{1}{6} \Delta \Gamma_2 T^2 + I.$$

for the reaction of the hydrogen iodide with the alkali of the glass, the source of his divergence may be in this factor, although his temperatures have been suspected. The divergence of the work of Rittenberg and Urey cannot be explained readily.

The value of  $\Delta E_0^0$  for hydrogen iodide obtained in this work results in a change in Blagg and Murphy's  $\Delta E_0^0$  for deuterium iodide (equation 1) from 1014.52 cal./mole to 1033.09 cal./mole =0.4%. This change in  $\Delta E_0^0$  merely shifts the theoretical curve parallel to itself, the final curve for DI being that shown in Fig. 5. The experimental data obtained for the equilibrium constant of DI are plotted, those data obtained with the final improved technique (the two points nearest the curve) falling on the curve within the same limits of precision as those for hydrogen. The three preliminary points are also in fair agreement. There are no experimental data by other workers.

**The Rate Constants of the Various Reactions.**

—The experimental data for the constants *k*<sub>1</sub> (formation) and *k*<sub>2</sub> (decomposition) for hydrogen iodide and deuterium iodide are given in Tables IV, and V, respectively, and in Fig. 6. The equilibrium constants required for the calculation are included in the tables.

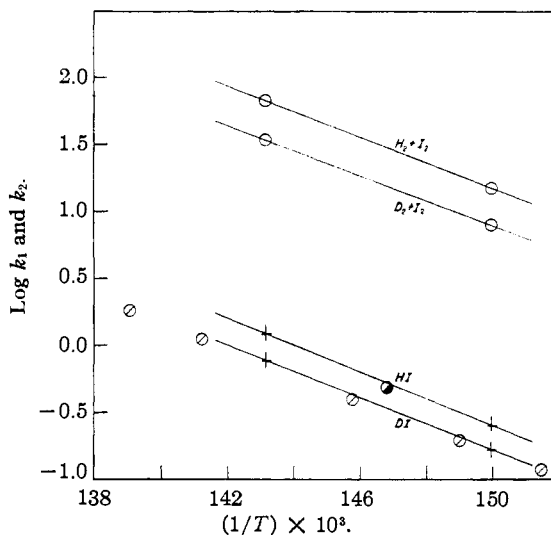

Fig. 6.—Reaction rates on the hydrogen and iodine systems: O, Taylor and Crist, combination *k*<sub>1</sub>; +, Taylor and Crist, decomposition *k*<sub>2</sub>; ⊖, Blagg and Murphy, decomposition DI; ●, Blagg and Murphy, decomposition HI.

Experiments were carried out at the two lower temperatures used for the equilibrium studies,

TABLE IV  
 THE RATE OF FORMATION OF HYDROGEN AND DEUTERIUM IODIDES

Gas	Temp., °K.	Cell	Time, sec.	Mol./cc. H <sub>2</sub> start × 10 <sup>4</sup>	Mol./cc. I <sub>2</sub> start × 10 <sup>4</sup>	Mol./cc. HI found × 10 <sup>4</sup>	k <sub>1</sub>	k <sub>1</sub> av.	K
H <sub>2</sub>	698.6	6	4500	1.0915	1.0086	1.2753	70.07		
		7	5400	1.0886	1.1802	1.4849	63.64		
		8	6600	1.1035	0.9710	1.4057	65.13	67.0	
D <sub>2</sub>	698.6	1	7200	1.1001	1.1947	1.6162	69.28	±2.7	0.01821
		5	3600	1.0997	1.2345	0.9529	33.54		
		1	7200	1.0995	1.1393	1.2733	34.66		
H <sub>2</sub>	666.8	8	10800	1.0982	1.0600	1.3906	34.91	34.47	
		7	10800	1.0973	1.0765	1.4020	34.75	±0.46	.02221
		7	7200	1.0968	1.0520	0.8035	15.58		
D <sub>2</sub>	666.8	2	9000	1.1077	1.2857	1.0732	15.50		
		5	9000	1.1120	1.2819	1.0728	15.46	15.59	
		6	12600	1.0937	0.9695	1.0299	15.82	±0.12	.01641
D <sub>2</sub>	666.8	2	7200	1.1075	1.0251	0.4967	7.946		
		8	10800	1.1008	1.1789	.7397	7.867		
		6	14400	1.1094	0.9392	.7544	8.073	7.950	
		8	18000	1.0967	1.2564	1.0567	7.914	±0.062	.02019

 TABLE V  
 THE RATE OF DECOMPOSITION OF HYDROGEN AND DEUTERIUM IODIDES

Gas	Temp., °K.	Cell	Time, sec.	Mol./cc. HI start × 10 <sup>4</sup>	Mol./cc. I <sub>2</sub> found	Z	k <sub>2</sub>	k <sub>2</sub> av.	K <sub>1/2</sub>
HI	698.6	7	7200	1.6812	0.09866	0.11734	1.204		
		6	9000	1.5680	.10368	.13225	1.224		
		5	10800	1.2178	.07787	.12789	1.250	1.242	
		2	12600	1.2031	.08602	.14300	1.289	±0.027	0.1350
DI	698.6	7	3600	2.0966	.05484	.05231	0.7395		
		8	7200	2.1654	.11169	.10316	.7765		
		2	10800	2.1273	.15025	.14126	.8019	0.777	
HI	666.8	6	10800	2.0732	.14142	.13643	.7822	±0.017	.1490
		1	14400	1.2267	.02609	.04254	.2715		
		8	16800	1.6543	.05232	.06325	.2488		
DI	666.8	2	18000	1.5187	.04800	.06322	.2528	0.259	
		5	22800	1.4285	.05436	.07610	.2622	±0.008	.1281
		2	14400	1.8537	.03906	.04214	.1661		
DI	666.8	6	21600	1.3786	.03346	.04853	.1731		
		1	21900	1.7770	.05247	.06157	.1657	0.1678	
		5	28800	1.9017	.07701	.08099	.1664	±0.0026	.1421

in order to minimize the error due to the period required for the cell to come to thermal equilibrium with the furnace. The same concentrations which were used in the first part of the present work were again employed.

The best estimate of the precision and reliability of these rate constants may be obtained by reference to their internal agreement as indicated in Tables IV and V.

It is now possible to give with certainty the ratios of the rate constants for hydrogen and deuterium iodides and to make a comparison of the previous experimental and theoretical ratios. This has been done in Table VI where the values indicated are those for the opposite reaction as calculated by equation (4). Close agreement has been obtained between the present

 TABLE VI  
 RATIOS OF THE RATES OF REACTION BY SEVERAL AUTHORS  
 666.8°K.                      700°K.

	k <sub>1HI</sub> /k <sub>1DI</sub>	k <sub>2HI</sub> /k <sub>2DI</sub>	k <sub>1HI</sub> /k <sub>1DI</sub>	k <sub>2HI</sub> /k <sub>2DI</sub>
Taylor and Crist	1.96	1.54	1.93	1.60
Taylor and Crist			1.96 <sup>a</sup>	1.58 <sup>a</sup>
Blagg and Murphy			1.88 <sup>a</sup>	1.53
Geib and Lendle			2.45	2.00 <sup>a</sup>
Wheeler, Topley and Eyring			2.34	1.92 <sup>a</sup>

<sup>a</sup> Calculated from the reverse reaction.

work and that of Blagg and Murphy, while the ratio of Geib and Lendle is shown to be considerably in error. The ratio of the rate constants as predicted by Wheeler, Topley and Eyring is also considerably higher than the present experimental value.

In an attempt to determine the nature of the



changes which will be required to bring the theoretical calculation into agreement with experiment, several arbitrary adjustments were made in the values calculated by the above authors. This procedure is employed by Eyring and co-workers.

A 50% decrease in the normal frequencies of the activated complex is not enough to give the desired value and the ratio of the reaction rate constants is even less sensitive to changes in the frequency normal to the barrier, *i. e.*, that frequency leading directly to reaction. If however  $E_{act.}$  for the two reactions is not the same then it is only necessary to have a difference of several hundred small calories to bring the ratios into agreement. This difference is somewhat less than the experimental error. It is thus apparent that more fundamental adjustments will be required in the theoretical calculation.

The authors are indebted to the National Research Council for a grant covering the purchase of the National Bureau of Standards' calibrated platinum resistance thermometer used in this work. They also wish to thank Professor

G. M. Murphy for helpful suggestions during the early stages of the work.

### Summary

The equilibrium constants for the dissociation of hydrogen and deuterium iodides have been determined for the temperature range 763.8 to 666.8°K. The results for the hydrogen iodide are in disagreement with the experimental work of Bodenstein. The slope of the  $\log K$  vs.  $1/T$  plot agrees with that calculated by Murphy and by correcting his equation for the new value of  $\Delta E_0^0$  for the dissociation, the curves are brought into coincidence. The data for deuterium iodide agree with the predictions based on the new  $\Delta E_0^0$  above and the zero point energies of the molecules concerned.

The ratios of the rate constants for hydrogen and deuterium, in both the combination and decomposition reactions, have been determined at 698.6 and 666.8°K. The results differ from those predicted by Wheeler, Topley and Eyring and from the experimental work of Geib and Lendle, while they are in agreement with that of Blagg and Murphy.

NEW YORK, N. Y.

RECEIVED FEBRUARY 11, 1941

[CONTRIBUTION FROM THE FRICK CHEMICAL LABORATORY, PRINCETON UNIVERSITY]

## III. Two-Component Gel Catalysts Containing Chromium Oxide for the Aromatization of *n*-Heptane

BY HAROLD FEHRER AND HUGH S. TAYLOR

Three types of material have been incorporated as a second component in chromium oxide gels: (a) the dehydrogenating metals copper, nickel and palladium, (b) the dehydrogenating metal oxides of manganese, zinc and molybdenum, (c) oxides such as silica, zirconia and stannic oxide, and these have been compared with standard chromium oxide gel.<sup>1</sup>

### Experimental Details

**Catalyst Preparations.**—Gels of chromium oxide with copper, nickel, zinc and manganese oxides, respectively, were obtained by addition of 0.166 *N* ammonium hydroxide solution to solutions 0.1 *N* in chromium nitrate and 0.1 *N* in the nitrate of the metal under study. For the molybdenum preparations the appropriate amount of ammonium paramolybdate was added to the chromic nitrate before precipitation with ammonia.

A 3% palladium-97% chromium oxide gel, by weight,

was prepared by immersing an equivalent amount of standard gel in the appropriate solution of palladium chloride. A chromium oxide-silica catalyst was prepared by stirring a 20% solution of sodium silicate into a 20% chromium nitrate solution containing ammonium acetate, the whole being brought to boiling and forming a jelly.

A group of gels containing 10% by weight of zirconia were prepared with the chromium oxide gel types examined in Part I. As typical of these ZrV was made by ethyl alcohol reduction of chromic acid solution with the requisite amount of zirconium oxynitrate added in three portions during the reduction process. In ZrIII the oxynitrate solution was added rapidly to the solution obtained by mixing concentrated solutions of ammonia and chromic acetate. ZrI was obtained by adding the gelatinous precipitate from ammonia and zirconium oxynitrate in three portions during the reduction of chromic acid with ethyl alcohol, stirring vigorously under reflux for several hours. The activity of zirconia alone was tested with a precipitate from zirconium oxynitrate (72 g./liter) with concentrated ammonia. Two catalysts incorporating 10% stannic oxide were tested to compare the effect of another Group IV oxide with that of zirconia.

(1) J. Turkevich, H. Fehrer and H. S. Taylor, *THIS JOURNAL*, **63**, 1129 (1. 41).